

8-bit Microcontrollers

KLCS-870/C Series

Suitable for home electrical appliances and cellular equipment which require low-voltage operation capability and low power consumption

Basic functions

- **64-Kbyte memory space**
 - : ROM-less version and versions including up to 60 Kbytes of ROM (all devices at planning stage)
- **Architecture suitable for real-time control**
 - : 0.25μs per instruction cycle at 16MHz
 - : Up to 15 interrupt vectors (23 with multiplexing between interrupt factors)
- **Low-voltage, high-speed operation ; low power consumption**
 - : Wide operating voltage range: 1.8V to 5.5V (standard type)
 - : Reduced power consumption (2/3 less compared to TLCS-870)
 - : Clock gear
 - High-frequency clock(6types), low-frequency clock(1type)
- **Instruction sets for embedded controller use : 731 instructions**
 - : Registers: isolated from memory space
 - : Variety of bit-manipulation instructions
 - : 16-bit transfer/calculation instructions
 - : Multiplication and division instructions
- **One-time PROM, E²PROM**
 - : PROM or E²PROM with features compatible with those of mask products
- **Small package**
 - : Microflat package/ Miniflat package
- **Measures to combat electrical noise**
 - : Reduces spontaneous noise, resistance to noise
- **Improvement in compilation of C source code**
 - : (24% compared to KLCS-870)
- **Well-developed support environment**
 - : Assembler
 - : High-level language (C compiler, C-Like compiler)
 - : High-level language debugger
 - : Real-time emulator: RTE Model 15

Register model

(Only a single general register bank is shown here)

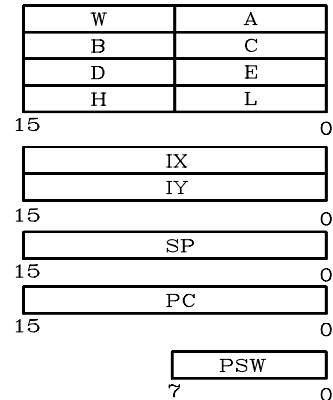

Comparison of power consumption levels

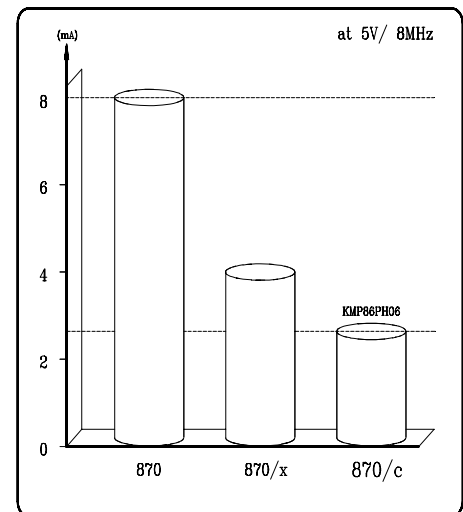

KLCS-870/C Series Selection Guide

ROM (byte)	RAM (byte)	Product No.	Minimum Instruction Execution Time (μs)	Driver			I ² C Bus Channels	A/D Converter			Timer/Counter	E ² PROM	Remote Control Pulse Detector	Watchdog Timer	Dual Clock	Number of I/O Ports	Clock Gear	Power Supply Voltage (V)	Operating Temperature (°C)	Built-in OTP	Package
				LED	LCD	VFT		8-bit Channels	10-bit Channels	18-bit Channels											
16k	512	*KMP86CH06N/U	0.2/122	8		2				1 2			● ● ●	● ● ●	35		1.8~5.5	-40~85	*KMP86PH06N/U	SDIP42/ μQFP44	
8k	512	KMP86C829U		32		1		8 1		4			● ● ●	● ● ●			1.8~5.5	-40~85	KMP86PM29U	μQFP44	
16k	1k	KMP86CH29U		32		1		8 1		4			● ● ●	● ● ●			1.8~5.5	-40~85	KMP86PM29U	μQFP44	
32k	1k	KMP86CM29U		32		1		8 1		4			● ● ●	● ● ●			1.8~5.5	-40~85	KMP86PM29U	μQFP44	
8k	256	KMP86C808N/M				1		4 1		2			● ● ●	● ● ●			1.8~5.5	-40~85	KMP86PH08N/M	SDIP28	
16k	512	KMP86CH08N/U				1		4 1		2			● ● ●	● ● ●			1.8~5.5	-40~85	KMP86PH08N/M	SOP28	